

**SWING CHECK VALVE
LEVER AND SPRING
4" & 6"**

MODEL 92LS-Class #125

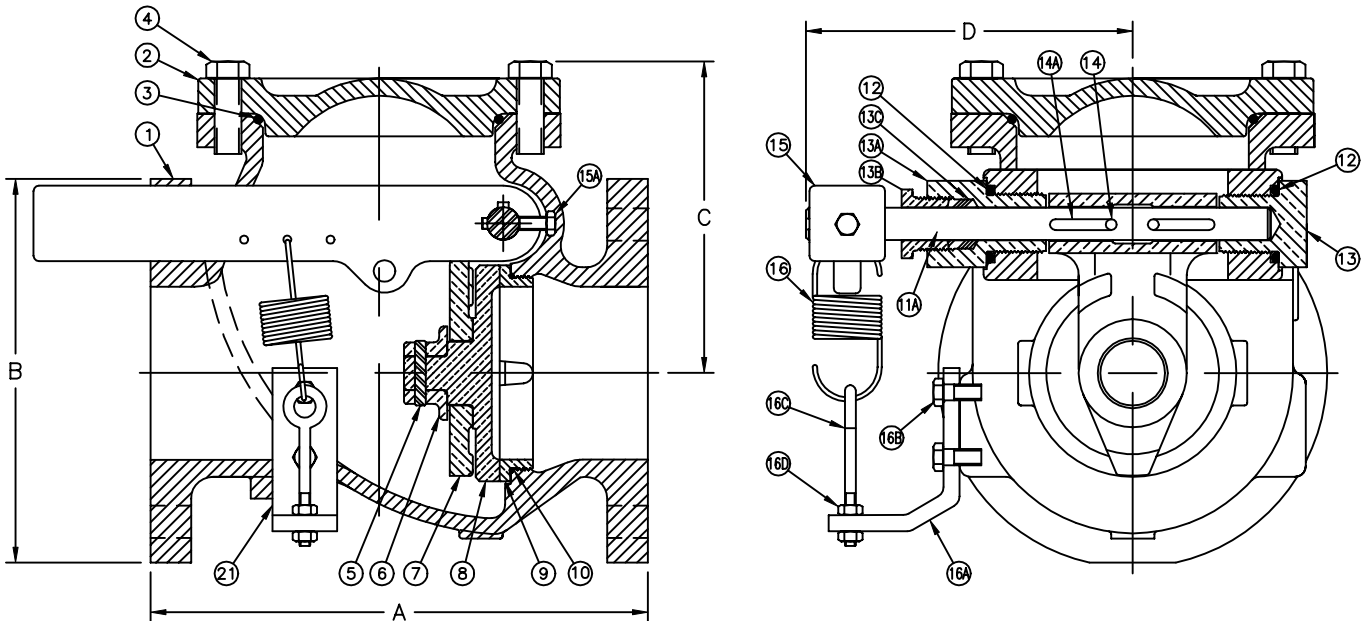

*OPTIONAL RESILIENT SEAT (NITRILE) AVAILABLE. ADD "R" TO THE PART NUMBER
FOR REFERENCE USE ONLY, SPECIFICATIONS SUBJECT TO CHANGE WITHOUT NOTICE.

SIZE(in.)	PART No.	A	B	C	D	WT. lbs.
4	3707LS	11 1/2	8 57/64	7 7/32	7 9/16	109
6	3709LS	14	10 3/4	8 17/32	8 17/32	195

ITEM	QTY.	DESCRIPTION	MATERIAL	ASTM #
1	1	BODY (EPOXY COATED)	CAST IRON	A126 CLASS B
2	1	COVER (EPOXY COATED)	CAST IRON	A126 CLASS B
3	1	COVER O-RING	BUNA-N	-----
4	4	COVER BOLTS	STAINLESS STEEL	18-8
5	1	FLAPPER END CAP PIN	STAINLESS STEEL	18-8
6	1	FLAPPER END CAP	FEDERALLOY	I-836-FL
7	1	HINGE LEVER ARM	FEDERALLOY	I-836-FL
8	1	*FLAPPER PLATE	FEDERALLOY	I-836-FL
9	1	SEAT RING	FEDERALLOY	I-836-FL
10	1	O-RING	BUNA-N	-----
11A	1	SHAFT SUPPORT SHAFT	STAINLESS STEEL	17-4 PH
12	2	O-RING	BUNA-N	-----
13	1	SHAFT SUPPORT BEARING	BRONZE	C93200
13A	1	OPEN ENDED SHAFT BEARING	BRONZE	C93200
13B	1	PACKING NUT	BRONZE	C93200
13C	4	PACKING	TEFLON	-----
14	1	1/4 -20 ALLEN HD SCREW	STAINLESS STEEL	18-8
14A	3	1/4" KEYS	STAINLESS STEEL	302
15	1	LEVER ARM (EPOXY COATED)	DUCTILE IRON	A536-84
15A	1	HHCS BOLT	STAINLESS STEEL	18-8
16	1	SPRING	STAINLESS STEEL	316
16A	1	SPRING BRACKET (EPOXY COATED)	STEEL	-----
16B	2	BRACKET BOLTS	ZNC PLT STEEL	-----
16C	1	EYE BOLT	ZNC PLT STEEL	-----
16D	2	EYE BOLT NUT	ZNC PLT STEEL	-----

FLOMATIC® DANFOSS FLOMATIC CORP
GLENS FALLS, N.Y. 12801
PHONE (518) 761-9797
FAX (518) 761-9798

MANUFACTURED IN
COMPLIANCE WITH
AWWA C508 STANDARD

DATE: 6/10/96
DWG. NO.: S3707LS
REV.: I (1/03)