

**BALL CHECK VALVE  
4" SIZE**

**MODEL 508/50**

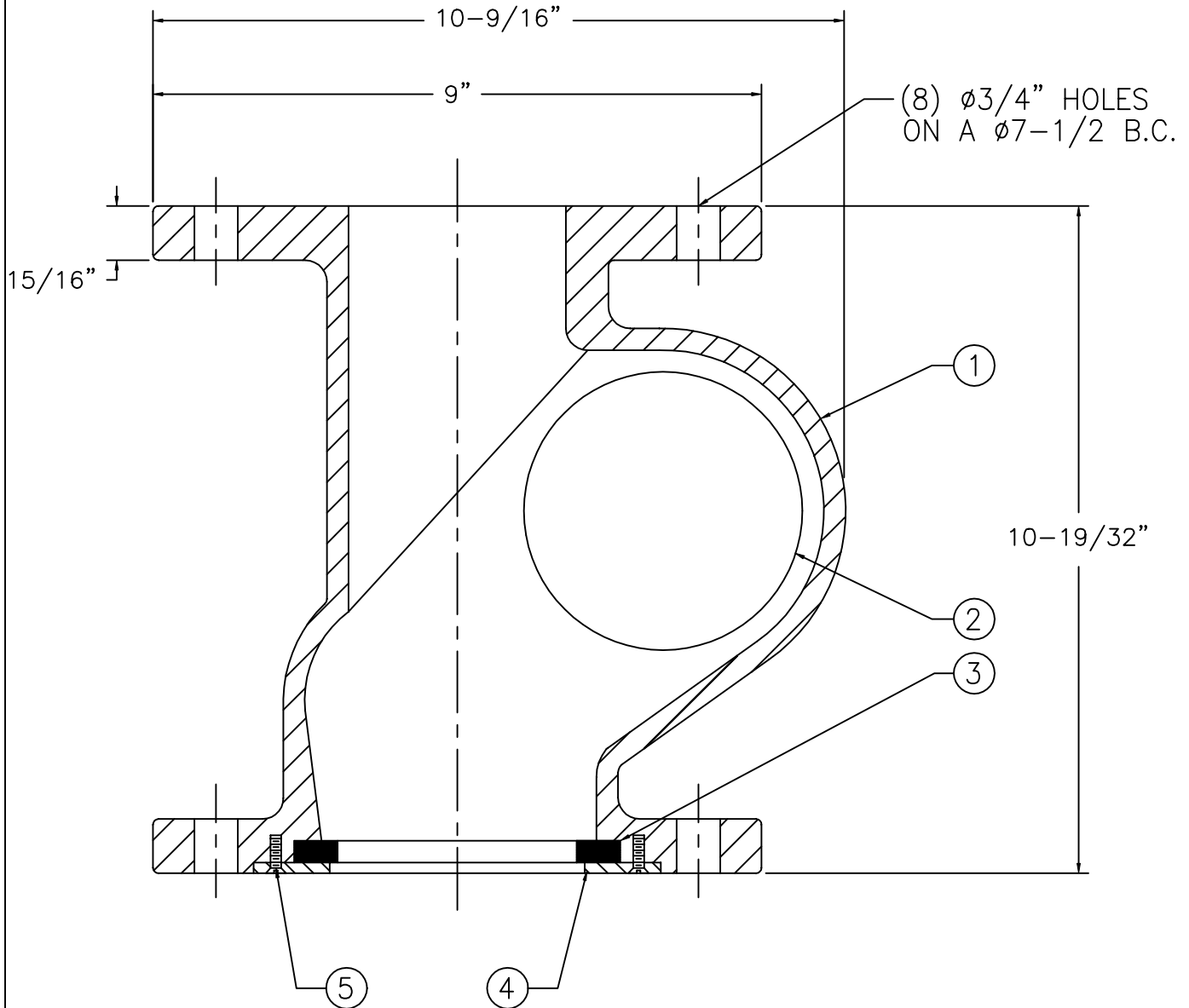

\*FLOATING BALL ALSO AVAILABLE, ADD "FB" TO PART NUMBER **WGT 45 LBS**  
 FOR REFERENCE USE ONLY, SPECIFICATIONS SUBJECT TO CHANGE WITHOUT NOTICE.

ITEM	QTY.	DESCRIPTION	MATERIAL	ASTM #
1	1	BODY (EPOXY COATED)	CAST IRON	A-126
2	1	*BALL	PHENOLIC	-----
3	1	SEAL	POLYURETHANE	-----
4	1	RETAINING RING	STAINLESS STEEL	304
5	4	FLAT HEAD SCREW	STAINLESS STEEL	18-8