



Fiberglass Basin Installation Reference Guide

PURPOSE

The purpose of this guide is to provide a brief reference to the recommended methods and procedures for installing Topp Industries, Inc. underground sump and sewage basins to ensure that damage or premature failure of the basin do not occur.

Studies conducted by both environmental regulatory agencies and trade organizations demonstrate that the most significant source of leaks and failures in underground storage systems is improper handling and installation. Proper handling and installation requires practical experience combined with strict adherence to proven methods and procedures.

This guide is **not** intended to serve as a basic instructional manual. The installation of our sump and sewage basins is a specialized skill, and is assumed that the individuals who install our products and refer to this guide will have basic understanding of such procedures as excavating, backfilling, pipefitting, and electrical work. No amount of written instruction by a manufacture or a regulatory agency will convert an inexperienced, under-supervised laborer into a skilled, experienced mechanic. The ability to recognize and correctly respond to abnormal conditions during a basin installation requires field experience as well as mechanical aptitude.

In addition to proper system engineering and competent manufacturing, the use of basin installers who have both practical experience and integrity to assist that the basin be installed properly constitutes the greatest protection from catastrophic basin failure and liability exposure.

DISCLAIMER

Every reasonable effort has been put forth by Topp Industries, Inc. and its agents to ensure the accuracy and reliability on the information contained in this reference guide. However, neither Topp Industries, Inc., its agents, nor its consultant make any representation, warranty, or guarantee in connection with the publication of these recommended methods and procedures. Topp Industries, Inc. hereby disclaims any liability for loss or damage resulting from their use; for the violation of any federal, state, county, or municipal regulations with which these recommended methods and procedures may conflict; or for the infringement of any patent resulting from the use of recommended methods and procedures.

MATERIAL HANDLING

➤ GENERAL HANDLING

Although the exterior surfaces of our fiberglass reinforced plastic (FRP) sump and sewage basins are designed, to withstand normal handling, they can be damaged during transportation and installation. Basins must not be dropped, dragged, or handled with sharp objects and with the exception of the minimal movement involved in a visual inspection, should not be rolled.

If the basin or its shell is damaged, installation should be suspended until Topp Industries, Inc. or its agent can make a determination of the extent of damage. Any repairs must be first authorized in writing by Topp Industries, Inc. and then be done in accordance with Topp Industries, Inc. instructions.

➤ UNLOADING, LIFTING, AND LOWERING

The proper way of moving a basin is by lifting it, using chains or cables with the optional lifting lugs (not more than 30* included angle) or by using a non-marring sling around the basin. Before any attempt is made to move a basin, it should be established that all of the equipment and accessories have sufficient capacity and reach to lift and lower the basins without dragging and/or dropping. Basins should be maneuvered with guide ropes attached to the sides.

WARNING !! Under NO, circumstances are the use of chains or cables around the basin shell permitted.

➤ STORAGE

Basins should be stored in a secure, controlled area where the potential for accidental damage or vandalism will be minimized. The storage area should be free from sharp objects, rocks and any other foreign solutions or materials that could cause damage to the basins. Chock the basins until they are needed for installation and if windy conditions are possible, secure the basins with non-marring restraints of a size and number adequate for securing the basin.

➤ PRE-INSTALLATION INSPECTION

Basins, vales, equipment, and piping materials should be physically and visually inspected before installation. Adherence to the project's specifications should also be confirmed before installation. If the basin or any of its internal components are damaged, installation should be suspended until a determination of the extent of damage can be made by Topp Industries, Inc. or its agent. Any repairs must be first authorized in writing by Topp Industries, Inc. and then be done in accordance with Topp Industries, Inc. instructions.



Fiberglass Basin Installation Reference Guide

EXCAVATING

➤ EXCAVATING

The excavation should provide adequate space for the basin, piping, and other buried equipment and for the replacement and compaction of backfill materials particularly around the basin walls. The size, shape and wall slope of the excavation should be determined by soil conditions, depth of excavation, shoring requirements, and if workers are required to enter the excavation, safety considerations and federal, state, county, and municipal regulations.

WARNING !! Locate all overhead and underground utilities before excavating

➤ LOCATION OF EXCAVATING

Excavation for an underground basin should be made with due care to avoid undermining foundations of existing structures and contact with underground utilities. In the absence of building codes or regulations, maintain a minimum distance of five feet plus a slope or 45* from the bottom of the compacted sub-base to the bottom of the adjacent structures, foundations, footings, and property lines (as shown in the attached illustration). Additional distances may be required to assure that any loading carried or created by the foundations and supports cannot be transferred to the basins.

➤ MAXIMUM BURIAL DEPTH

If burial depth is greater than the basin height, contact Topp Industries, Inc. to determine if additional wall reinforcement is required and secure written authorization.

➤ HANDLING OF EXCAVATED MATERIALS

Excavated materials, which cannot be removed from the jobsite, should be carefully stored as far from the edge of the basin excavation as possible. Unless approved for use as backfill, excavation materials should be securely stored separate from the approved backfill materials.

➤ WORK AREA SAFETY

Safe installation procedures shall be the sole responsibility of the basin installer. Work safety requirements are defined in U.S. Department of Labor 29 CFR part 1926, subpart P, Excavations.

BACKFILLING

➤ GENERAL

Careful selection, placement, and compaction of approved backfill material is critical to a successful basin installation. Among the common problems associated with basin leaks and premature failures are:

- Use of incorrect backfill material
- Inadequate or improper placement or compaction
- Rocks, clods, or debris left in the excavation or basin
- Voids under or around the perimeter of the basin
- Failure to prevent the migration of backfill materials

➤ PLACEMENT OF BASIN

The bottom of the basin excavation should be covered with suitably with graded, leveled, and compacted backfill material to a depth of at least 12 inches (compacted sub-base). If a concrete hold-down/anti-flotation pad is required, this bedding can be reduced to a depth of at least 6 inches. The carefully lower the basin into the excavation and centered on the compacted backfill or concrete pad (see attached).

WARNING !! Placement of a basin on a concrete pad or compacted sub-base smaller than the total basin bottom area or on intermediate supports (saddles) will cause uneven distribution of loads.

This may contribute to structural failure, and is never permitted.

➤ BACKFILL MATERIAL

Back fill material should be clean, well granulated, free flowing, non-corrosive, and inert. It should be free of ice, snow, debris, rock, or organic material, all of which could damage the tank and interfere with the compaction of the backfill material. The largest particles should not be larger than 3/4". Not more than 3% (by weight) should pass through a # 8 sieve, and the backfill material should conform to ASTM C-33, Paragraph 9.1 requirements. Approved backfill materials include:

- Pea Gravel, naturally rounded particles with a minimum diameter of 1/8" and a maximum diameter of 3/4".
- Crushed rock, washed and free-flowing angular particles between 3/8" and 1/2" in size.



Fiberglass Basin Installation Reference Guide

BACKFILLING (continued)

➤ PLACEMENT AND COMPACTION OF BACKFILL

Compaction of backfill materials should be adequate to ensure the support of the tank, and to prevent movement or settlement. Backfill materials should be placed in 12" lifts and compacted to a minimum soil modulus of 700 pounds per square inch (psi)

➤ SUPPORTING PIPING, EQUIPMENT AND ACCESSORIES

Support for piping, equipment and other accessories must be provided during backfilling. Using the basin to support piping, equipment, cribbing, bracing, or blocking is never permitted. During backfilling, temporary supporting materials must be carefully installed and removed to prevent damage to the basin, piping, or equipment.

WARNING !! Using the basin to support any loading carried or created by piping, equipment, cribbing, bracing, or blocking is never permitted.

ANCHORAGE

➤ GENERAL

When basin installations are located in areas subject to high water tables or flooding, provisions should be made to prevent the basins, either empty or filled, from floating. The buoyancy force to be offset is determined primarily by the volume of the basin. The principle offsetting factors include:

- Backfill materials
- Concrete hold-down pad
- Friction between the tank, backfill materials and the surrounding soil

➤ METHODS OF ANCHORAGE

All methods of anchoring basins use the weight of the backfill materials to offset the buoyancy forces. The use of supplemental mechanical anchoring methods (a concrete hold-down pad) increases the amount of backfill ballast, which is mechanically, attached to the basin. The recommended method of attachment is to pour concrete grout over the basin's anti-floatation flange and concrete grout over the basin's anti-floatation flange and concrete hold-down pad (see attached illustration)

➤ ANCHORAGE REQUIREMENTS

Requirements of anchorage, thickness of concrete hold-down pads, as well as the size of anchors and reinforcement must be calculated for each installation based on the environmental conditions of that specific installation.

WARNING !! Use "submerged" material weights when calculating anchorage requirements.
Example: weight of concrete (150 pounds per cubic foot) minus the weight of the water (62.4 pounds per cubic foot) equals a "submerged" weight of 87.6 pounds per cubic foot.

FOR ADDITIONAL INFORMATION PLEASE CONTACT:

Topp Industries, Inc.

P.O. Box 420 - 420 N. State Rd 25 - Rochester, IN 46975

Toll Free (800) 354-4534 / (219) 223-3681 / Fax (219) 223-6106

E-mail: toppindustries@toppindustries.com / Web-site: www.toppindustries.com

Fiberglass Basin Installation Reference Guide



FIBERGLASS BASIN INSTALLATION REFERENCE GUIDE

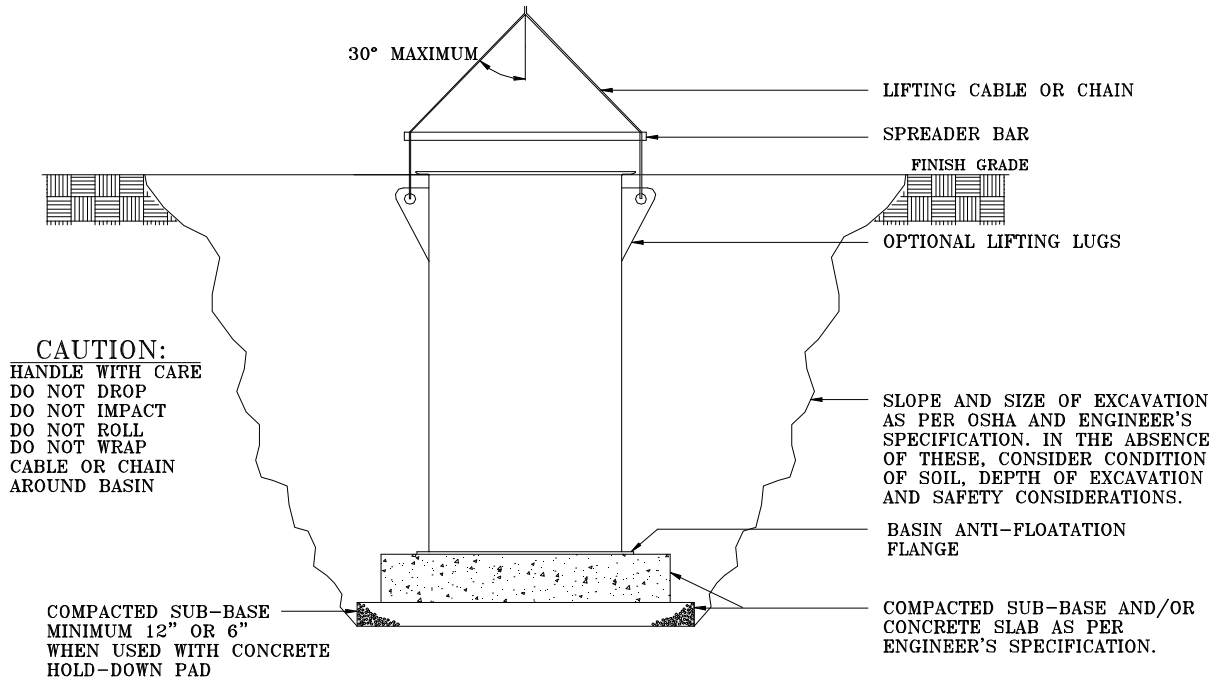

CAUTION:
HANDLE WITH CARE
DO NOT DROP
DO NOT IMPACT
DO NOT ROLL
DO NOT WRAP
CABLE OR CHAIN
AROUND BASIN

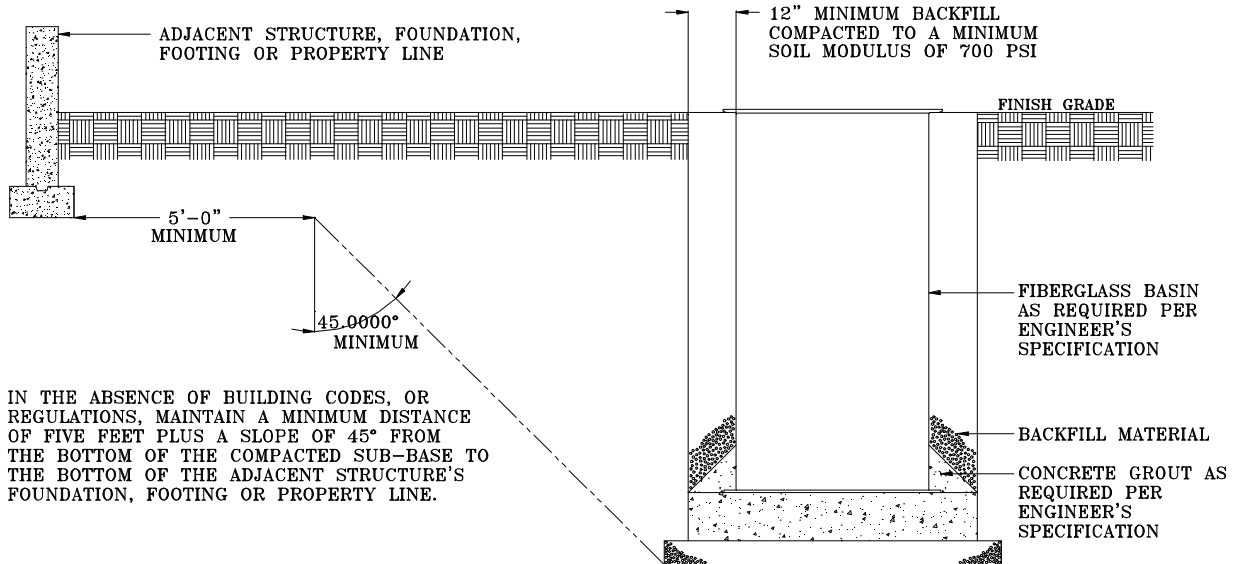

IN THE ABSENCE OF BUILDING CODES, OR REGULATIONS, MAINTAIN A MINIMUM DISTANCE OF FIVE FEET PLUS A SLOPE OF 45° FROM THE BOTTOM OF THE COMPACTED SUB-BASE TO THE BOTTOM OF THE ADJACENT STRUCTURE'S FOUNDATION, FOOTING OR PROPERTY LINE.

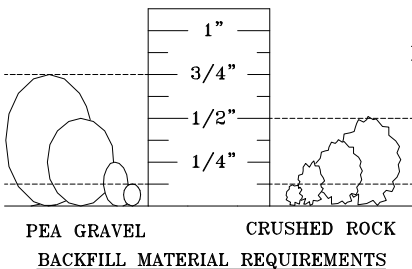

NOTE:

The intent of these installation instructions and illustrations is to ensure that damage or premature failure to the basin will not occur. These installation instructions and illustrations are NOT intended to preclude normal safety procedures which should be followed to prevent injury to personnel. SAFE INSTALLATION PROCEDURES SHALL BE ENTIRELY THE RESPONSIBILITY OF THE INSTALLER.